

# SureLock™

## LM Series Compact Wavelength Stabilized Laser Modules

Attalon LM Series Laser Modules are engineered to be ultra-compact, durable, and user-friendly, making them ideal for OEM integration. Featuring the Attalon SureLock™ Laser, the LM Series ensures steady, spectrum-narrowed performance with exceptional stability across the full power range, from 0% to 100%. Single mode models offer cost-effective single frequency performance. All SureLock™ Series lasers are stabilized by the Attalon PowerLocker™ Volume Holographic Grating (VHG), providing precise, ultra-stable center wavelengths with minimal temperature dependence and consistent optical performance.

The LM Series offers both remote computer and local manual controls, for adjusting precise temperature and current regulations. It achieves better than 1% power stability and has a warm-up time of less than a few minutes, ensuring quick and reliable operation. Fiber coupling and isolators are available options to facilitate integration into any analytical instrument application. Designed for both laboratory and OEM use, the LM Series Laser Modules maintain consistent stability and performance across the entire power range, making them perfect for analytical and spectroscopy applications where stability and reliability are crucial.



### FEATURES

- Single mode offers single frequency spectral performance with long coherence length (~1 m)
- Plug and play operation with remote computer and onboard user controls with integral LCD Display
- Simplify setup complexity and insure consistent results with integrated drive electronics and temperature control
- Ultra-compact footprint
- Customized wavelength options available
- Optional isolator option for some models
- Optional singlemode fiber coupling output
  - PM or SM with FC/APC connector

### APPLICATIONS

- Raman Spectroscopy
- Interferometry
- Metrology
- HeNe Replacement
- Bio-Instrumentation
- Particle Characterization
- Graphic Arts
- Sensing
- Analytical Instrumentation

Specifications	405 nm 12 mW	405 nm 40 mW	633 nm 40 mW	633 nm 70 mW
SKU (OEM)	115-81040-150	115-81040-140	115-81040-083	115-81040-073
SKU (Non-OEM w/ keyswitch)	115-81040-650	115-81040-640	115-81040-583	115-81040-573
Output Power, Maximum (mW)	12	40	40	70
Center Wavelength <sup>1</sup> (nm)				
Minimum	404.5	404.5	632.5	632.5
Typical	405	405	633	633
Maximum	405.5	405.5	633.5	633.5
Beam Size, Typical (mm)	0.75 x 0.45	0.75 x 0.45	0.6x0.9	0.6x0.9
Linewidth, Typical (MHz)	160	160	150	150
Spatial Mode	Single Transverse Mode			
Polarization, Minimum	Option for 100:1			
Polarization, Typical	100:1	100:1	100:1	100:1
Beam Divergence (mrad)				
Typical	1.2	1.2	0.8	0.8
Maximum	2	2	1.5	1.5
Noise (%) (RMS, 0-20MHz)				
Typical	0.25	0.25	0.25	0.25
Maximum	0.5	0.5	0.5	0.5
Power Stability, Typical (%) (5 hour)	3	3	3	3
<b>Operating Requirements</b>				
Operating Current, Maximum	1.5	1.5	1.5	1.5
Operating Voltage (VDC)				
Minimum	3.1	3.1	3.1	3.1
Maximum	12	12	12	12
Modulation Input Voltage (V) (TTL)				
Minimum	0	0	0	0
Maximum	5	5	5	5
Modulation Speed (KHz)				
Minimum	0	0	0	0
Maximum	3	3	3	3
Storage Temperature (°C)				
Minimum	-10	-10	-10	-10
Maximum	60	60	60	60
Operating Temperature (°C)				
Minimum	10	10	10	10
Typical	25	25	25	25
Maximum	40	40	40	40
Operation Humidity	Non-Condensing			

All specifications are at rated power with a case temperature within stabilized temperature range unless otherwise noted.

<sup>1</sup> Wavelengths specified are vacuum referenced. Ex 632.991nm vacuum referenced is equivalent to 632.816nm standard air referenced for HeNe

Specifications	638 nm 120 mW	690 nm 40 mW	785 nm 100 mW
SKU (OEM)	115-81040-184	115-81040-069	115-81040-177
SKU (Non-OEM w/ keyswitch)	115-81040-684	115-81040-569	115-81040-677
Output Power, Maximum (mW)	120	40	100
Center Wavelength <sup>1</sup> (nm)			
Minimum	637.5	689	784.5
Typical	638	690	785
Maximum	638.5	691	785.5
Beam Size, Typical (mm)	0.6x0.9	0.9x1.5	0.9x1.7
Linewidth, Typical (MHz)	300	100	300
Spatial Mode	Single Transverse Mode		
Polarization, Minimum	Option for 100:1		
Polarization, Typical	100:1	100:1	100:1
Beam Divergence (mrad)			
Typical	0.8	1	1
Maximum	1.5	3	3
Noise (%) (RMS, 0-20MHz)			
Typical	0.25	0.25	0.25
Maximum	0.5	0.5	0.5
Power Stability, Typical (%) (5 hour)	3	3	3
<b>Operating Requirements</b>			
Operating Current, Maximum	1.5	1.5	1.5
Operating Voltage (VDC)			
Minimum	3.1	3.1	3.1
Maximum	12	12	12
Modulation Input Voltage (V) (TTL)			
Minimum	0	0	0
Maximum	5	5	5
Modulation Speed (KHz)			
Minimum	0	0	0
Maximum	3	3	3
Storage Temperature (°C)			
Minimum	-10	-10	-10
Maximum	60	60	60
Operating Temperature (°C)			
Minimum	10	10	10
Typical	25	25	25
Maximum	40	40	40
Operation Humidity	Non-Condensing		

All specifications are at rated power with a case temperature within stabilized temperature range unless otherwise noted.

<sup>1</sup> Wavelengths specified are vacuum referenced. Ex 632.991nm vacuum referenced is equivalent to 632.816nm standard air referenced for HeNe

Specifications	LM With Isolator		
	633 nm Isolator	638 nm Isolator	785 nm Isolator
SKU (OEM)	115-81040-192	115-81040-193	115-81040-189
SKU (Non-OEM w/ keyswitch)	115-81040-692	115-81040-693	115-81040-689
Output Power, Maximum (mW)	60	110	150
Center Wavelength <sup>1</sup> (nm)			
Minimum	632.5	637.5	784.5
Typical	633	638	785
Maximum	633.5	638.5	785.5
Beam Size, Typical (mm)	0.6x0.9	0.6x0.9	1.5x1.5
Linewidth, Typical (MHz)	150	300	300
Spatial Mode	Single Transverse Mode		
Polarization, Minimum	100:1	100:1	100:1
Beam Divergence (mrad)			
Typical	0.8	0.8	0.9
Maximum	1.5	1.5	1.5
Noise (%) (RMS, 0-20MHz)			
Typical	0.25	0.25	0.25
Maximum	0.5	0.5	0.5
Power Stability, Typical (%) (5 hour)	3	3	3
<b>Operating Requirements</b>			
Operating Current, Maximum	1.5	1.5	1.5
Operating Voltage (VDC)			
Minimum	3.1	3.1	3.1
Maximum	12	12	12
Modulation Input Voltage (V) (TTL)			
Minimum	0	0	0
Maximum	5	5	5
Modulation Speed (KHz)			
Minimum	0	0	0
Maximum	3	3	3
Storage Temperature (°C)			
Minimum	-10	-10	-10
Maximum	50	50	50
Operating Temperature (°C)			
Minimum	10	10	10
Typical	25	25	25
Maximum	40	40	40
Operation Humidity	Non-Condensing		

All specifications are at rated power with a case temperature within stabilized temperature range unless otherwise noted.

<sup>1</sup>Wavelengths specified are vacuum referenced. Ex 632.991nm vacuum referenced is equivalent to 632.816nm standard air referenced for HeNe

Specifications	LMFC With Fiber		
	633 nm FC/APC	638 nm FC/APC	785 nm FC/APC
SKU (OEM)	115-81040-154	115-81040-173	115-81040-176
SKU (Non-OEM w/ keyswitch)	115-81040-654	115-81040-673	115-81040-676
Output Power, Maximum (mW)	25	25	30
Center Wavelength <sup>1</sup> (nm)			
Minimum	632.5	637.5	784.5
Typical	633	638	785
Maximum	633.5	638.5	785.5
Linewidth, Typical (MHz)	150	300	300
Spatial Mode	PM Fiber 1m Long FC/APC		
Fiber Type	3/125	4/125	5/125
Polarization, Typical	100:1	100:1	100:1
Noise (%) (RMS, 0-20MHz)			
Typical	0.25	0.25	0.25
Maximum	0.5	0.5	0.5
Power Stability, Typical (%) (5 hour)	3	3	3
<b>Operating Requirements</b>			
Operating Current, Maximum	1.5	1.5	1.5
Operating Voltage (VDC)			
Minimum	3.1	3.1	3.1
Maximum	12	12	12
Modulation Input Voltage (V) (TTL)			
Minimum	0	0	0
Maximum	5	5	5
Modulation Speed (KHz)			
Minimum	0	0	0
Maximum	3	3	3
Storage Temperature (°C)			
Minimum	-10	-10	-10
Maximum	60	60	60
Operating Temperature (°C)			
Minimum	10	10	10
Typical	25	25	25
Maximum	40	40	40
Operation Humidity	Non-Condensing		

All specifications are at rated power with a case temperature within stabilized temperature range unless otherwise noted.

<sup>1</sup> Wavelengths specified are vacuum referenced. Ex 632.991nm vacuum referenced is equivalent to 632.816nm standard air referenced for HeNe

Typical Performance Data

Wavelength Stability  
(405 nm Example)

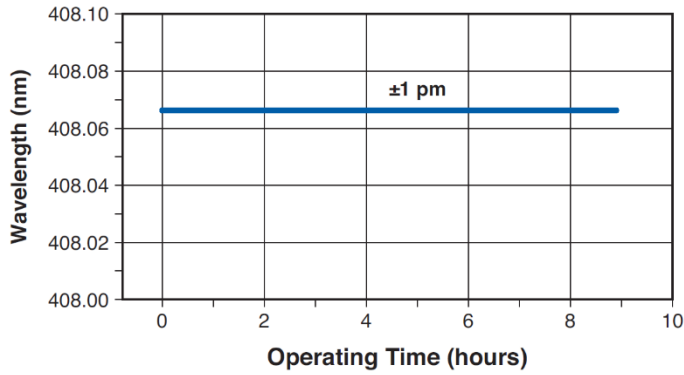

Optical Power Stability  
(405 nm Example)

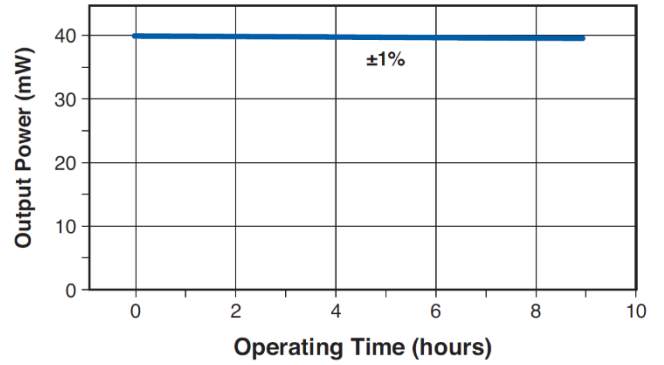

Wavelength Stability  
(785 nm Example)

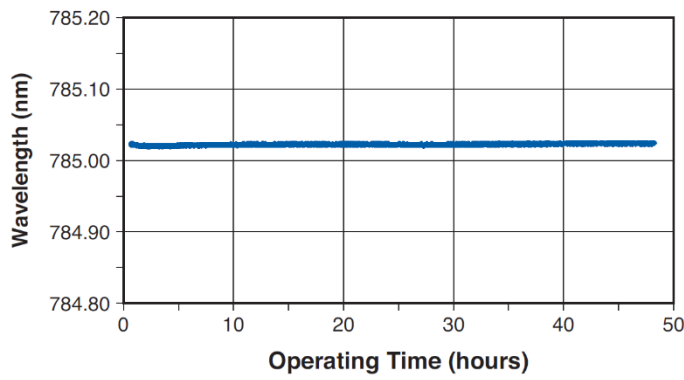

Optical Spectrum  
(405 nm Example)

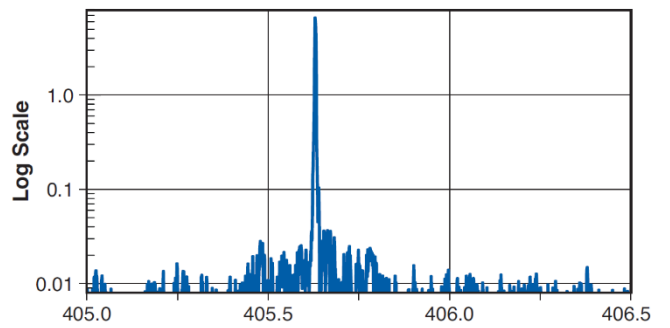

Optical Spectrum  
(633 nm Example)

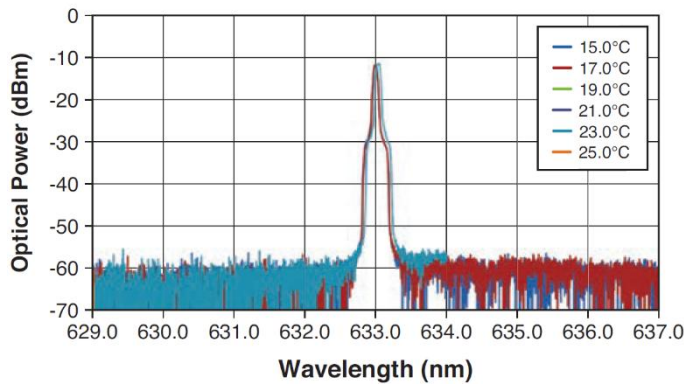

Optical Spectrum  
(785 nm Example)

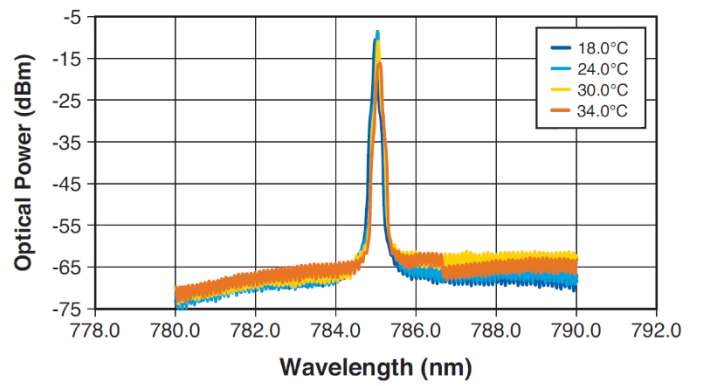

Accessories

Keyswitch (-K): This option is required for all non-OEM customers within the United States.

Keyswitch



Mechanical Specifications

LM Series Laser Module Standard Configuration

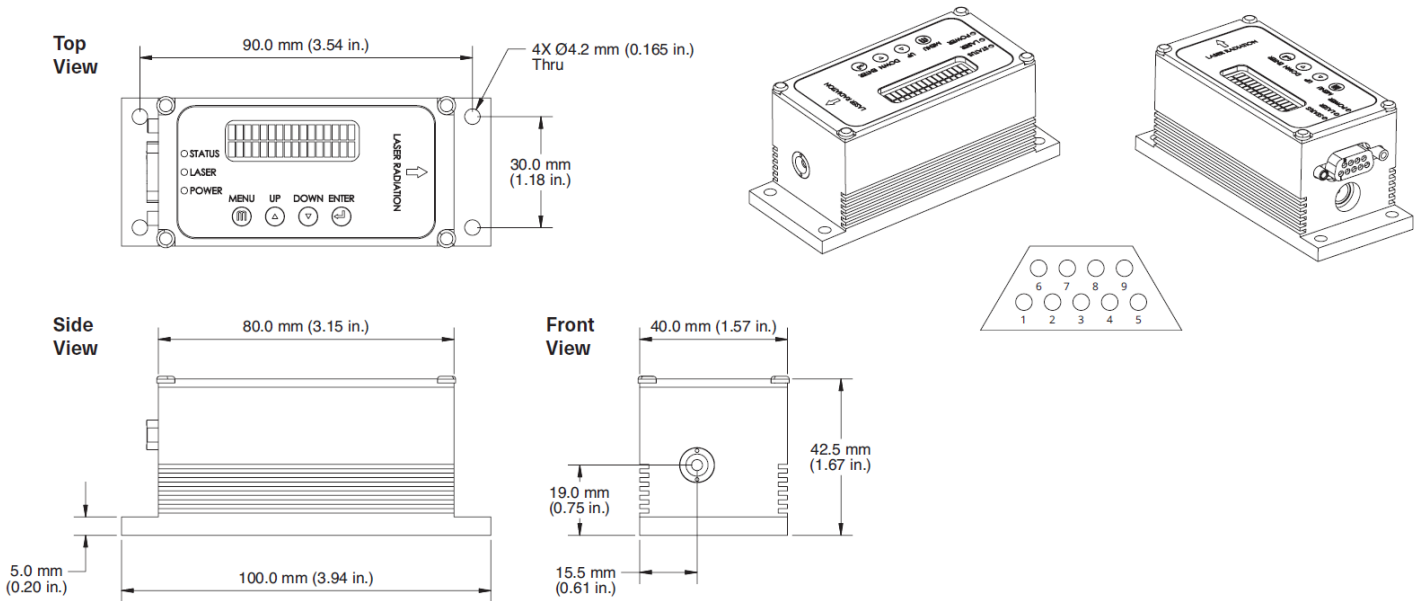

**LM Series Laser Module Fiber Pigtailed Configuration**

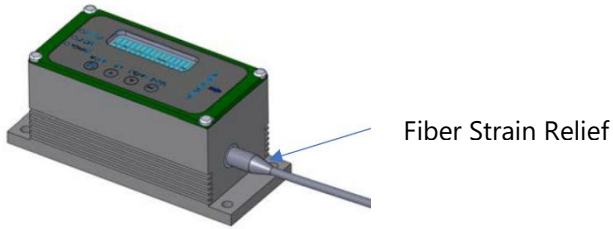

**LM Series Laser Module with Isolator Configuration**

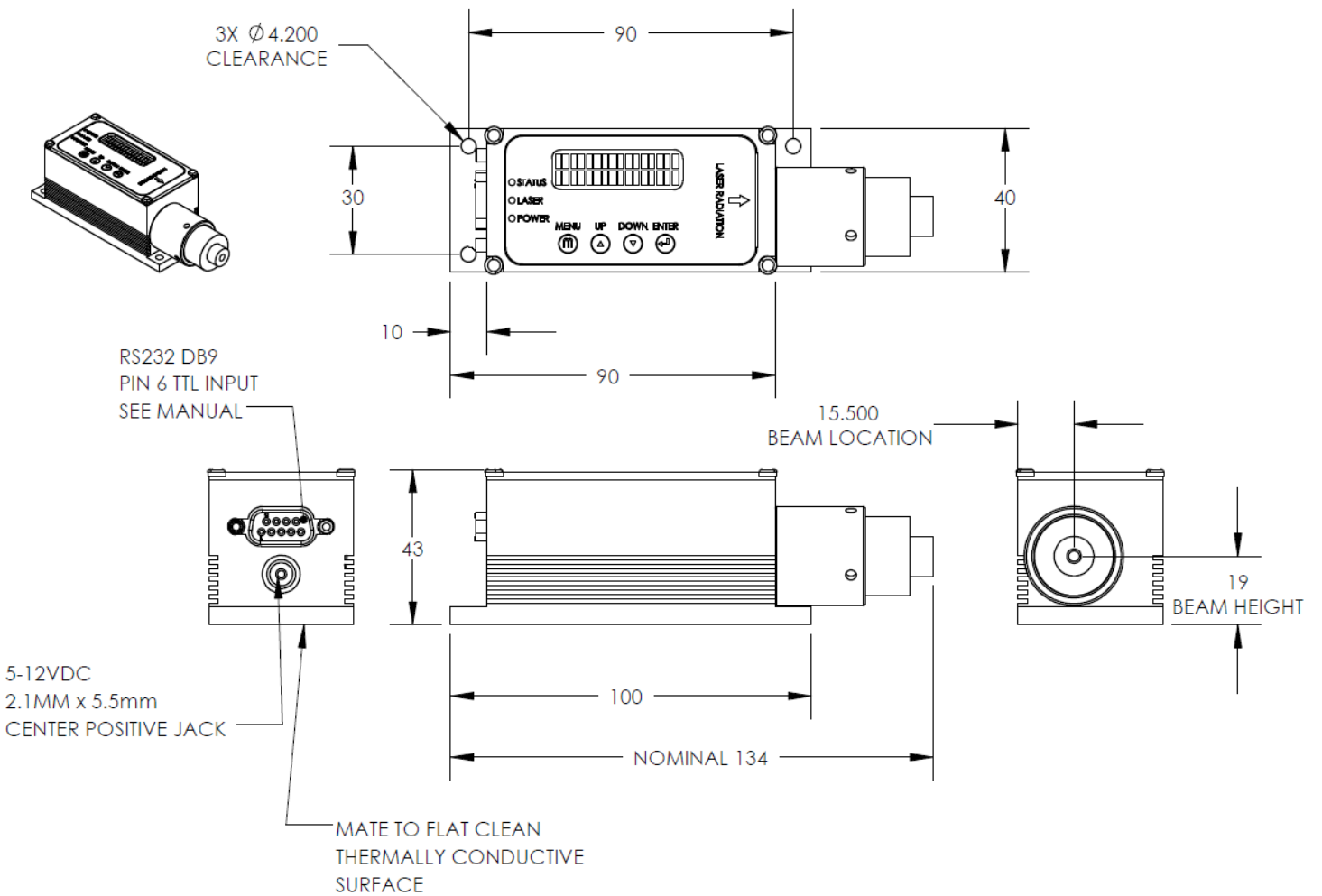

Pinout <sup>1</sup>		
Pin	Definition	Description
1	VCC	Positive Power Pin Vin
2	TXD	Send data to computer (RS-232)
3	RXD	Receive data from computer (RS-232)
4		Not used
5	GND	GND for power and RS-232 communication
6	TTL	Outside TTL modulation
7		Not used
8		Not used
9	GND	GND for power and RS-232 communication

<sup>1</sup>Pinout is compatible with Standard RS232 cable for interfacing with computer port or USB to RS-232 adapter

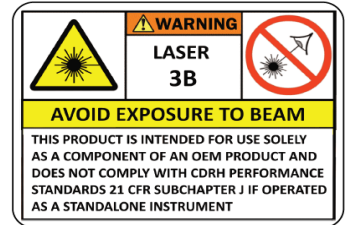

**Warnings:**

**Laser Eye Safety:** Use protective eyewear and follow local regulatory requirements for use of laser diodes.

**Remote Control Limitations:** Values entered via RS232 are not limit or type checked. Improper use may result in permanent damage to the laser diode.

**Environmental Conditions:** Units are designed to be mounted on a heat sink. Improper mounting can lead to permanent damage due to overheating or thermal runaway. For airflow based thermal dissipation, ensure there is sufficient clearance around heatsink. Please note that damage resulting from improper use is not covered under warranty.

To enhance optical stability, minimize airflow around the unit, particularly near the optical aperture. Although the internal external cavity laser is temperature stabilized, ambient conditions can impact performance. Reducing air currents will further improve stability. Covering of the laser and beam path may improve performance in conditions where there are rapid changes in the environment.

**Optical Feedback (for single mode units without optical isolators):** Semiconductor laser diodes are highly sensitive to optical feedback, which can cause latent damage that may not be immediately apparent. Wavelength-stabilized laser diodes are particularly vulnerable and may lose their spectral characteristics, such as center wavelength and linewidth, when exposed to sufficient optical feedback.

To prevent these issues, optical isolators must be used in applications where optical feedback is intrinsic. Avoid focusing the light output on highly reflective surfaces, as this generates optical feedback to the laser diode. For fiber-coupled applications, angled and anti-reflective (AR) coated fiber tips are recommended. All reflective surfaces in the optical path should be angled to prevent reflections from being directed back to the laser diode.

During optical alignments near normal incidence, use an optical isolator or optical density (OD) filter to eliminate the risk of brief high-intensity optical feedback. Be cautious with wavelength-sensitive elements such as narrow bandpass filters. Angularly sweeping the alignment of such elements can cause sufficient feedback to briefly unlock the diodes which would generate high-intensity reflected off-wavelength light, significantly increasing the risk of damage to the laser diode.

**Fiber Tip Cleanliness:** Inspect and clean all fiber tips before mate. Dirty or contaminated fiber tips could cause permanent damage to fiber connector. Cover all fiber tips when not in use. Damage to fiber or fiber connector is not covered by warranty.

**Mode Hops for Single Mode Laser Models:** To minimize mode hops in single-frequency lasers, it is crucial to control environmental conditions and eliminate optical feedback as these factors can induce mode hops, a sudden change in power and wavelength. However, even with these precautions, mode hops may still occur, especially as the diode ages and its characteristics change over time. Suitable solutions are dependent on application and may involve calibration routines or integration of appropriate sensors.